

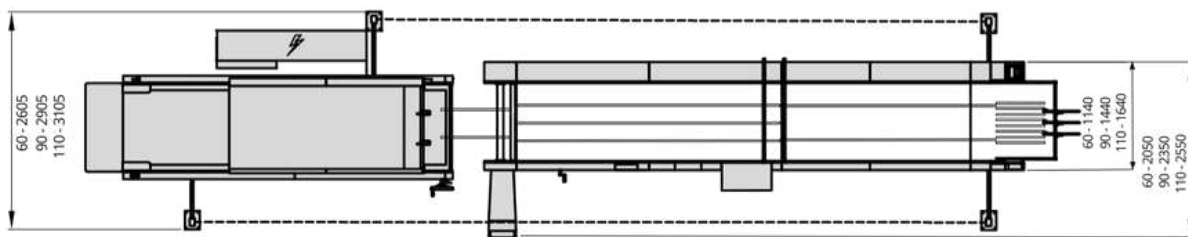

VEGA

B E L L A T R I X 6 0 • 9 0 • 1 1 0



PIEGATRICE-INCOLLATRICE PER SCATOLE IN CARTONE TESO E ONDULATO
FOLDING AND GLUING MACHINE FOR SOLID AND CORRUGATED BOARD BOXES



Caratteristiche tecniche / Technical Data		BELLATRIX 60	BELLATRIX 90	BELLATRIX 110
Fustellato aperto / Open blank	max mm	620	920	1120
	min mm	116	116	116
	min* mm	66	66	66
Fustellato chiuso / Folded blank	max mm	300	450	550
	min mm	55	55	55
	min* mm	30	30	30
Altezza / Blank length	max mm	800	800	800
	min mm	55	55	55
Materiale lavorato / Convertible material		g/m ² 180 ÷ 800 N-F-E-B		
Rompipiega / Prefolding section		150°		
Velocità / Speed	m/min	18 ÷ 400		
Motore a velocità variabile / Variable speed motor	kW	22		
Aria compressa / Compressed air	bar	6		
Peso netto / Net weight	kN	67	77	83
*Con dispositivo astucci piccoli / *With minimum folding boxes device				

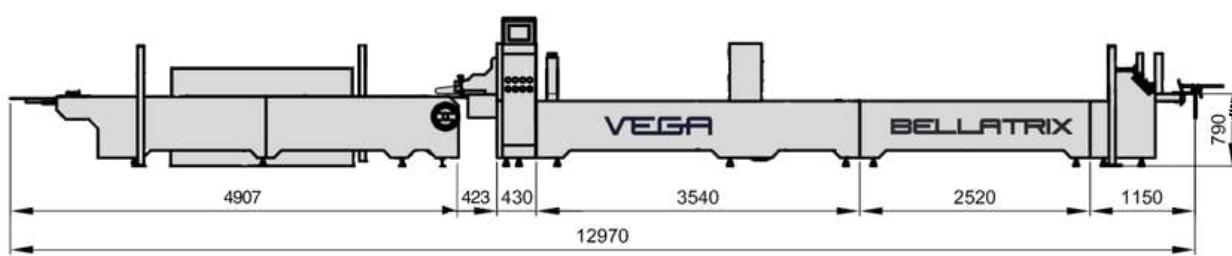
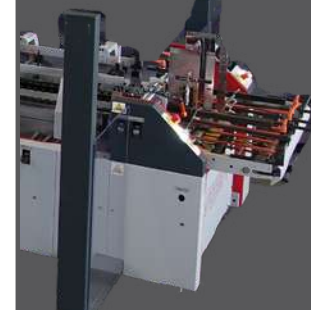

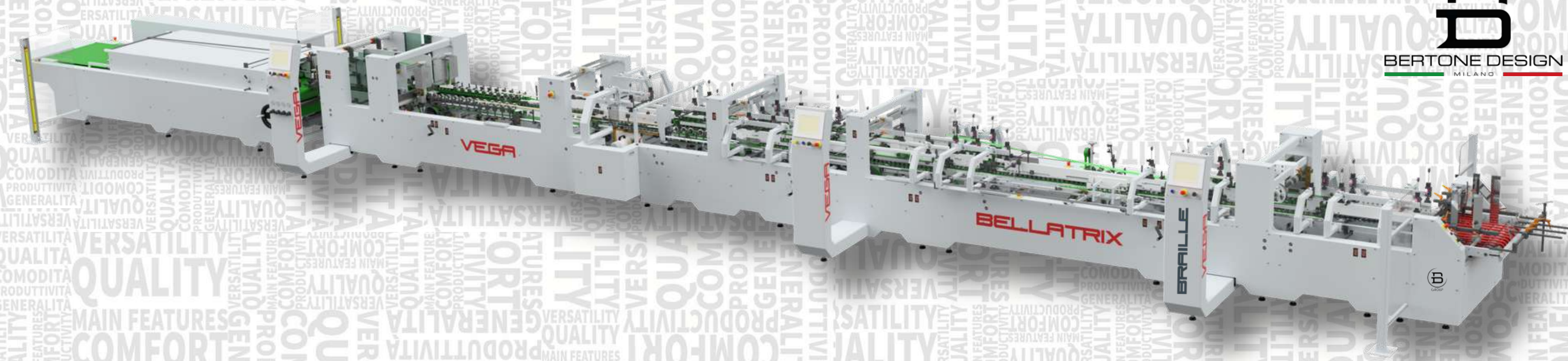

B E L L A T R I X 6 0 • 9 0 • 1 1 0

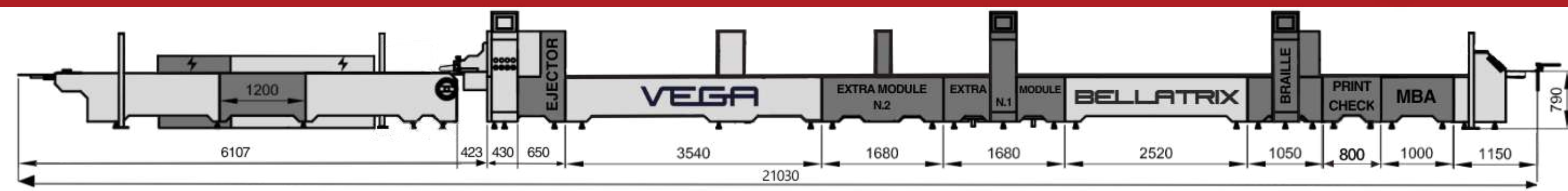

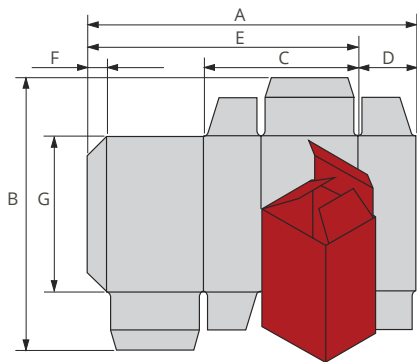

*Con dispositivo astucci piccoli
*With minimum folding boxes device

	min mm	VEGA 60 MAX mm	VEGA 90 MAX mm	VEGA 110 MAX mm
A	116	620	920	1120
B	55	800	800	800
C	55	300	450	550
D	10	180	330	430
E	-	520	820	1020
F	6	20	20	20
G	-	650	650	650
A*	66	-	-	-
C*	30	-	-	-

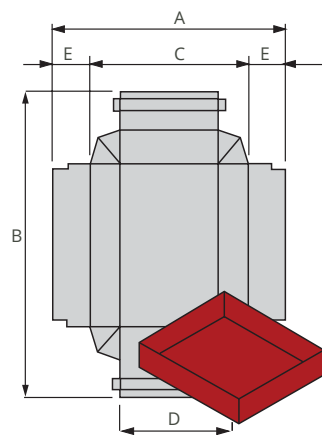

	min mm	VEGA 60 MAX mm	VEGA 90 MAX mm	VEGA 110 MAX mm
A	170	500	800	1000
B	55	800	800	800
C	130	-	-	-
D	90	400	700	900
E	20	80	80	80

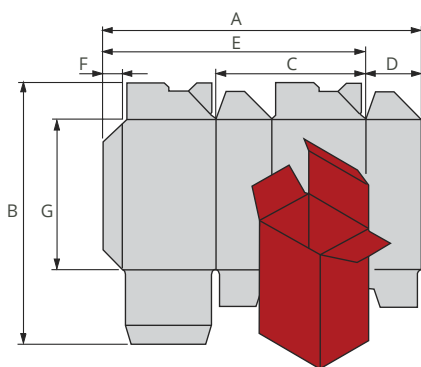

	min mm	VEGA 60 MAX mm	VEGA 90 MAX mm	VEGA 110 MAX mm
A	150	620	920	1120
B	-	800	800	800
C	70	300	450	550
D	35	150	225	275
E	-	520	820	1020
F	10	20	20	20
G	55	-	-	-

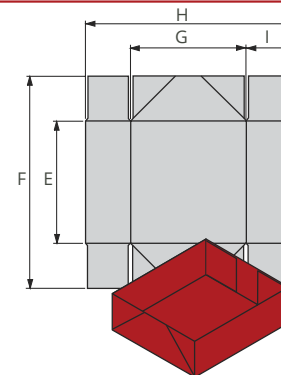

	min mm	VEGA 60 MAX mm	VEGA 90 MAX mm	VEGA 110 MAX mm
E	80	700	700	700
F	130	800	800	800
G	80	450	700	900
H	130	600	900	1100
I	25	150	150	150

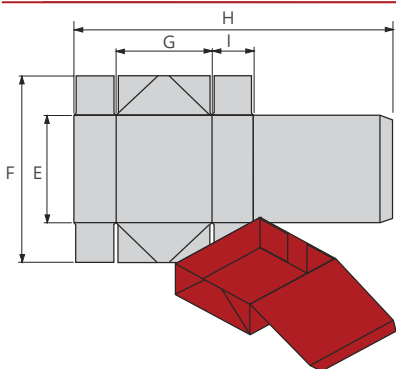

	min mm	VEGA 60 MAX mm	VEGA 90 MAX mm	VEGA 110 MAX mm
E	80	550	550	550
F	130	600	600	600
G	80	240	365	465
H	220	600	900	1100
I	25	150	150	150

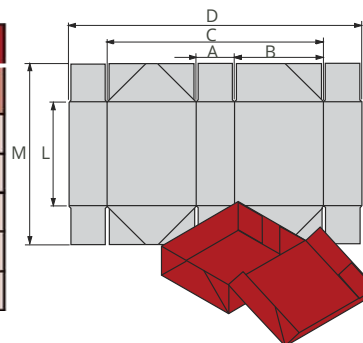

	min mm	VEGA 60 MAX mm	VEGA 90 MAX mm	VEGA 110 MAX mm
A	30	100	100	100
B	100	215	365	465
C	230	460	760	960
D	290	600	900	1100
L	80	400	400	400
M	160	600	600	600

BELLATRIX macchina piega-incolla modulare per astucci, scatole con fondo a chiusura automatica, doppia parete, 4/6 angoli. La macchina può essere fornita con una vasta gamma di moduli extra e accessori per piegare svariate tipologie di scatole speciali. Tecnologia VEGA, design Bertone Design Italia.

BELLATRIX folder-gluer machine for straight line, crash lock bottom, double wall and 4/6 corners boxes. The machine can be supplied with a set of attachments and extra modules for folding special carton styles. VEGA Technology, Bertone Italia Design.



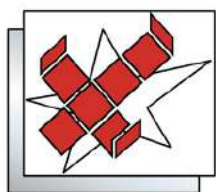

VEGA
CONNECTING NEEDS TO SOLUTIONS

MACCHINE PER CARTOTECNICA
SOLID AND CORRUGATED BOARD MACHINES



VEGA S.R.L.

VIALE DELL'INDUSTRIA, 6 ▪ 20037 PADERNO DUGNANO ▪ MILANO ▪ ITALY
TEL. +39 02 99046212 ▪ FAX +39 02 99046202
COMM@VEGAGROUP.IT ▪ WWW.VEGAGROUP.IT